

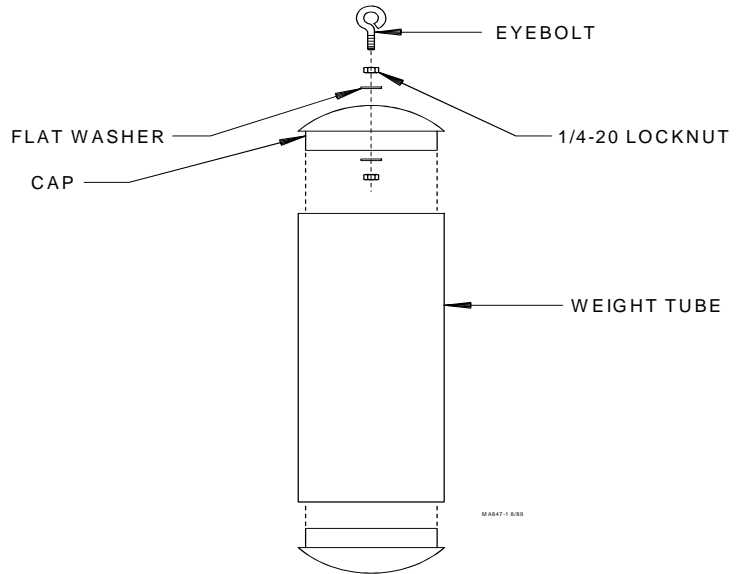

26051 Weight Kit Assembly Instruction

Assembly Instructions

1. Drill a 17/64" (6.7 mm) or 9/32" (7 mm) hole in center of one cap.
2. Assemble the cap and hardware as shown in the figure at right.
3. Cement the bottom cap in place, using PVC cement. Apply PVC cement according to the instruction with the cement to insure a good hold.
4. Fill tube with sand, rocks, or other high density material.
5. Cement the top cap in place. Allow the joints to dry prior to hanging the weight kit.



DESCRIPTION	PART NUMBER
EYEBOLT	22911
1/4-20 LOCKNUT	1269
FLAT WASHER	3239
CAP	24926
WEIGHT TUBE	26052

Contact your nearby Chore-Time distributor or representative for additional parts and information.
 Chore-Time Equipment, A Division of CTB, Inc.
 P.O. Box 2000, Milford, Indiana 46542-2000 U.S.A.

MA847A-1089



26051 Weight Kit Assembly Instruction

Assembly Instructions

1. Drill a 17/64" (6.7 mm) or 9/32" (7 mm) hole in center of one cap.
2. Assemble the cap and hardware as shown in the figure at right.
3. Cement the bottom cap in place, using PVC cement. Apply PVC cement according to the instruction with the cement to insure a good hold.
4. Fill tube with sand, rocks, or other high density material.
5. Cement the top cap in place. Allow the joints to dry prior to hanging the weight kit.

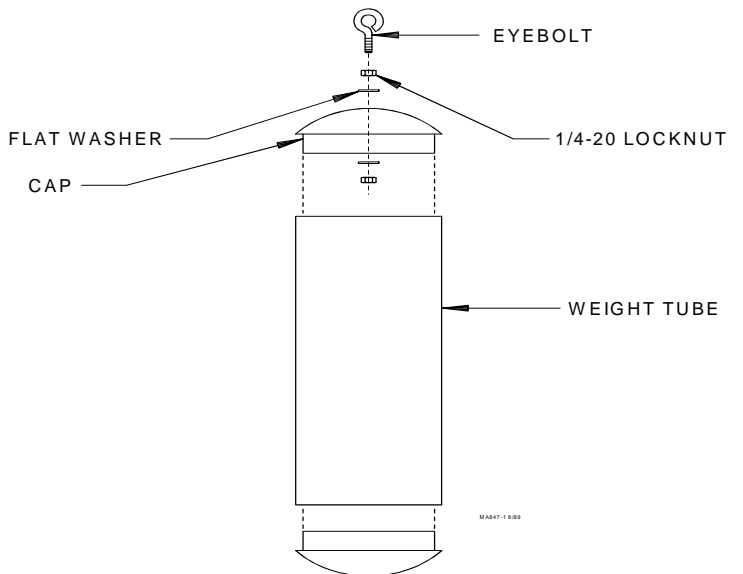

DESCRIPTION	PART NUMBER
EYEBOLT	22911
1/4-20 LOCKNUT	1269
FLAT WASHER	3239
CAP	24926
WEIGHT TUBE	26052

Contact your nearby Chore-Time distributor or representative for additional parts and information.
 Chore-Time Equipment, A Division of CTB, Inc.
 P.O. Box 2000, Milford, Indiana 46542-2000 U.S.A.

MA847A-1089