



Weight Kit Assembly Instruction

Part Number 26051

Assembly Instructions

1. Drill a 17/64" [6.7 mm] or 9/32" [7 mm] hole in center of one cap.
2. Assemble the cap and hardware as shown in the figure at right.
3. Cement the bottom cap in place, using PVC cement. Apply PVC cement according to the instruction with the cement to insure a good hold.
4. Fill tube with sand, rocks, or other high density material.
5. Cement the top cap in place. allow the joints to dry prior to hanging the weight kit.

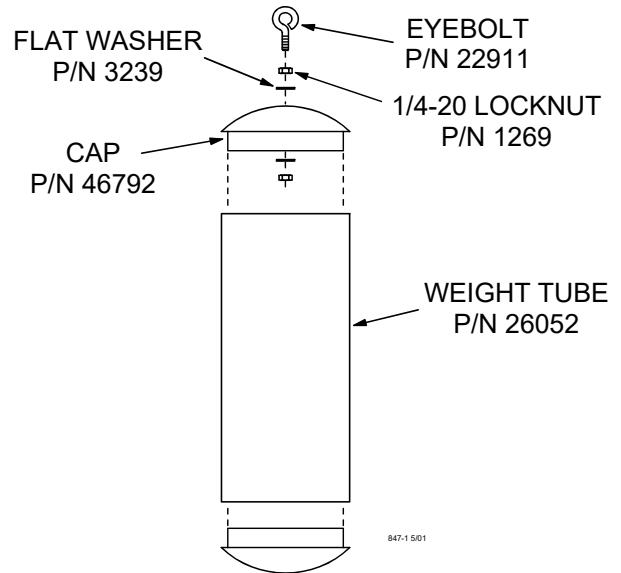

Chore-Time Group, A division of CTB, Inc.
PO Box 2000

Milford, Indiana 46542-2000 USA

Phone (574) 658-4101 Fax (877) 730-8825

Email: choretime@choretime.com / Internet: www.choretime.com

March 2019

MA847C



Weight Kit Assembly Instruction

Part Number

Assembly Instructions

1. Drill a 17/64" [6.7 mm] or 9/32" [7 mm] hole in center of one cap.
2. Assemble the cap and hardware as shown in the figure at right.
3. Cement the bottom cap in place, using PVC cement. Apply PVC cement according to the instruction with the cement to insure a good hold.
4. Fill tube with sand, rocks, or other high density material.
5. Cement the top cap in place. allow the joints to dry prior to hanging the weight kit.

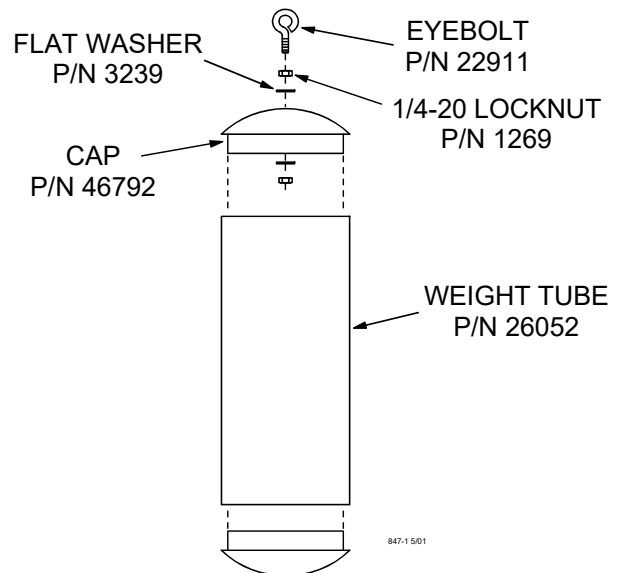

Chore-Time Group, A division of CTB, Inc.
PO Box 2000

Milford, Indiana 46542-2000 USA

Phone (574) 658-4101 Fax (877) 730-8825

Email: choretime@choretime.com / Internet: www.choretime.com

March 2019

MA847C